

Hydraulics & Pneumatics

THE JOURNAL OF FLUID POWER AND SYSTEMS

www.hpmag.co.uk

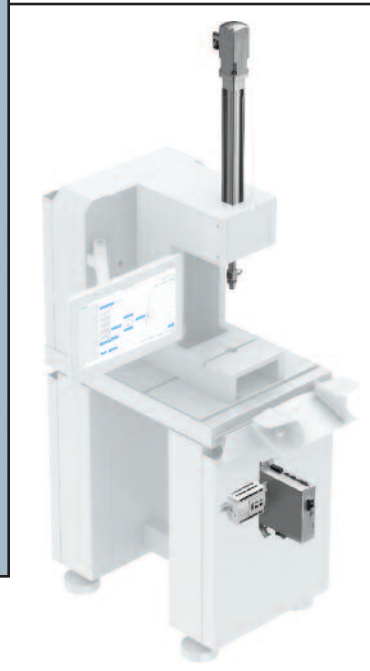
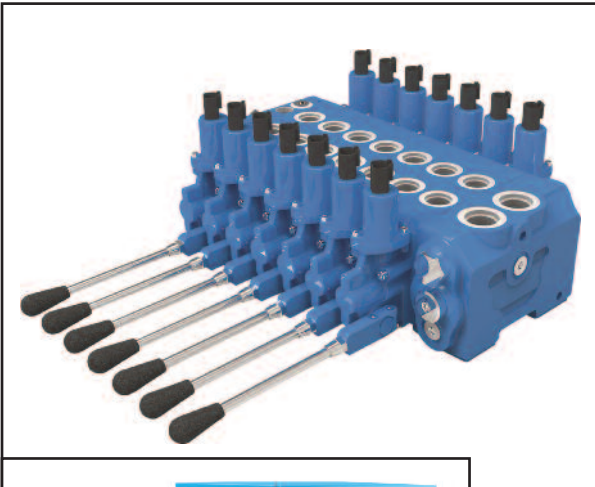

MEDIA INFORMATION 2018

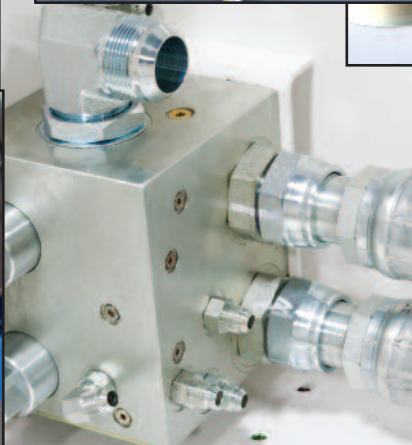
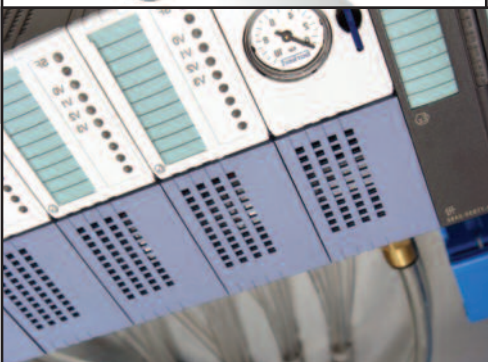
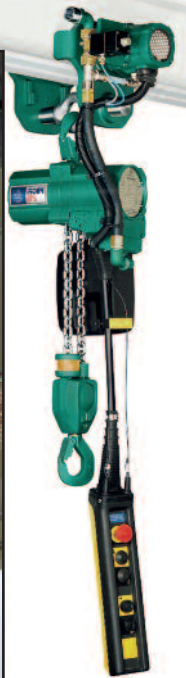

Hydraulics & Pneumatics

THE JOURNAL OF FLUID POWER AND SYSTEMS

Hydraulics & Pneumatics

Hydraulics & Pneumatics is the UK's only niche magazine for fluid power buyers and users within industrial and mobile sectors such as manufacturing, engineering, construction and transport.

The journal offers comprehensive updates on current developments concerning fluid power/motion control and related computerised technologies through the latest news, technical articles, topical opinion, in-depth interviews, new products and informative end user-focused application stories.

Current trends concerning hydraulic and pneumatic power, actuation, automation and associated electronics application are aired, along with compressed air generation and supply – plus relevant instrumentation, and systems control and monitoring. The publication also provides useful help and guidance on issues such as maintenance, repair & refurbishment, condition monitoring, energy efficiency, training and health & safety.

In addition, the journal publishes the annual Hydraulics & Pneumatics Buyers' Guide; an unrivalled sourcing and procurement aid for fluid power systems, components and services.

Hydraulics & Pneumatics magazine has strong links with leading trade associations the British Fluid Power Association (BFPA), the British Compressed Air Society (BCAS) and the British Valve & Actuator Association (BVAA). Moreover, Hydraulics & Pneumatics magazine owner DFA media is also the official publisher of the BFPA Yearbook and Members' Directory, and the Official BCAS Compressed Air & Vacuum Technology Guide, copies of which are distributed once a year together with Hydraulics & Pneumatics magazine.



Ed Holden Editor

Editorial Programme

2018 ISSUES	HYDRAULICS	PNEUMATICS	COMPRESSED AIR, VACUUM AND GENERATORS	INTERGRATED SYSTEMS	APPLICATIONS	KNOWLEDGE BASE	SPECIAL REPORTS
	MOBILE & INDUSTRIAL						
JANUARY/ FEBRUARY	Hose & Fittings, Power packs, Motors, Pumps	Every issue: The latest pneumatic products: Accessories, Actuators, Air lines, Air motors, FRLs, Seals, Vacuum, Valves/valve islands, Pneumatic control.	Every issue: The latest compressed air & vacuum products Air treatment, Compressors, Hose & fittings.	Process Change Management	Aerospace/ Defence	Offshore/ Onshore	Boardroom Report Fluid Power & Systems and Air-Tech Preview
MARCH	Cylinders, Seals, Filters, Valves			Industry 4.0 & Smart Factory	Medical/Food	Construction/ Off-Highway	Fluid Power & Systems and Air-Tech Catalogue
APRIL	Fluid Analysis Kits, Hose Fittings/Reels, Swaging			Electro-Pneumatic Systems	Automation for Fluid Power	Apprenticeships	Railway Focus Fluid Power & Systems and Air-Tech Review
MAY/JUNE	Valves, Pumps & P/packs, Heat Exchangers			Electro-Hydraulic Systems	Training	Agriculture	Mobile Equipment
JULY/AUGUST	Hose & Fittings/Reels, Cylinders, Lubrication			Process Change Management	Automotive/ Marine	Maintenance, Repair & Refurbishment	Primary Engineer Apprenticeship Scheme
H&P ANNUAL BUYERS GUIDE EDITION							
SEPTEMBER	Accumulators, Seals, Pumps & P/packs, Motors	Every issue: The latest pneumatic products: Accessories, Actuators, Air lines, Air motors, FRLs, Seals, Vacuum, Valves/valve islands, Pneumatic control.	Every issue: The latest compressed air & Vacuum products Air treatment, Compressors, Hose & fittings.	Industry 4.0 & Smart Factory	Agriculture	Automation for Fluid Power	2019 BFPA Yearbook & Members' Directory
OCTOBER	Hose Fittings/ Reels, Swaging, Valves			System Modelling & Simulation	Health & Safety	Energy Efficiency & Safety	Valve Actuator Focus BCAS Compressed Air & Vacuum Technology Guide
NOVEMBER/ DECEMBER	Heat Exchangers, Filters, Fluid Analysis Kits			Electro-Hydraulic Systems	Apprenticeships	Agriculture	LAMMA Preview Southern Manufacturing Preview

2018 Production / Publishing Dates

ISSUE	EDITORIAL	ADVERTISING	PUBLISHING DATE
JANUARY / FEBRUARY	26 JANUARY	2 FEBRUARY	16 FEBRUARY
MARCH	5 MARCH	12 MARCH	26 MARCH
APRIL	17 APRIL	24 APRIL	8 MAY
MAY/JUNE	29 MAY	4 JUNE	18 JUNE
JULY / AUGUST	27 JULY	3 AUGUST	17 AUGUST
SEPTEMBER	4 SEPTEMBER	11 SEPTEMBER	25 SEPTEMBER
OCTOBER	5 OCTOBER	12 OCTOBER	26 OCTOBER
NOVEMBER / DECEMBER	9 NOVEMBER	16 NOVEMBER	30 NOVEMBER

PRODUCTION DATA

Printed web offset.

Advertising copy may be supplied in most popular software packages. Copy may be supplied on a CD. Copy may also be supplied via email.

Cancellation: 4 weeks preceding the publication date.

Folding or extra cutting/trimming of inserts will be charged at cost.

Cover mounts, bound and loose insert details available on request.

Any queries, regarding supply of material, reproduction, etc., please contact Chelsea Moss. Tel: 01732 370340
Fax: 01732 360034 email: chelsea.moss@dfamedia.co.uk

Circulation Profile

Qualified Readers: 10,000

Main Activity

Description

Aerospace	326
Agriculture	385
Automotive/Auto Components	744
Banking, Insurance & Commerce	87
Bricks, Pottery, Glass and Cement	91
Chemicals & Process Control	525
Construction	345
Consulting, Professional & Scientific Services	604
Defence	168
Education	95
Electrical/Electronic Manufacturing	767
Food, Drink & Tobacco	439
Gas, Water, Electricity & Nuclear	511
Health Services/Medical	165
Instrument Engineering/Manufacture	520
Mechanical Engineering	704
Metal Production	574
Mining & Quarrying	108
Oil Production & Exploration	464
Pharmaceutical Industry	202
Printing, Paper & Packaging	171
Public Admin / Local Authority	52
Shipbuilding & Marine Engineering	149
Textiles, Clothing & Footwear	359
Transport & Communications	118
Warehouse & Distribution	782
Other	545

GEO Code

Description

EAST ANGLIA	478
EAST MIDLANDS	1143
LONDON	128
MIDLANDS	1903
NORTHERN IRELAND	103
NORTHERN	1027
NORTH WEST	457
SCOTLAND	483
SOUTH EAST	1937
SOUTH WEST	960
WALES	408
YORKSHIRE	973

Totals 10000

Primary Job Function

Description

Consultant	616
Design/Project Engineer	3095
Education/Training	152
Energy Management	136
General Engineer	392
Environmental Engineer	45
General/Corporate Management	520
Handling, Storage & Logistics	25
Health & Safety	425
Instrument, Control or Electrical Engineer	559
Maintenance Engineer	144
Process Engineer	692
Production/Mechanical Engineer	455
Purchasing	327
Recruitment/Personnel/HR	35
Research & Development	1101
Sales & Marketing	1045
Works/Plant Engineer	152
Other	84

TOTAL 10,000

Company Size

Description

1 - 49	5017
50-99	1481
100 - 199	1390
200 - 499	1066
500 - 999	411
1000+	635

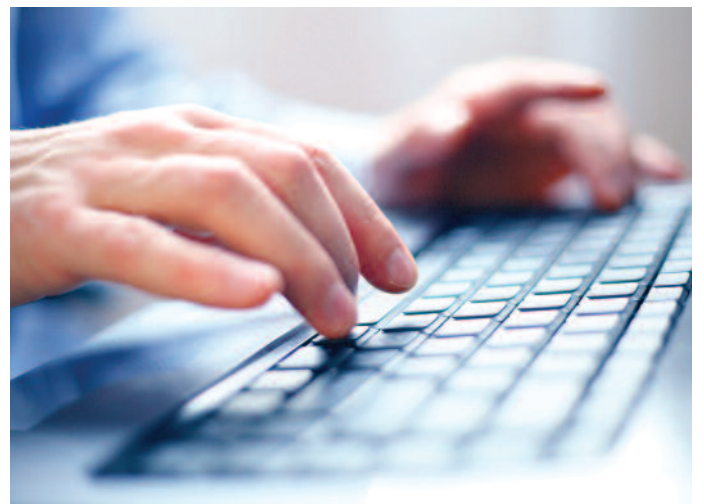

Advertising Rates

Hydraulics & Pneumatics Display Advertising gives your company the opportunity to promote a prominent and distinct image to the market.

Ability to time your promotion throughout the year

Target 10,000 qualified professionals in UK fluid power industry

Be seen amongst main players in the market

Full colour production

Plan promotion to coincide with relevant topics – see Editorial Program 2018

Create or Sustain profile(s) Proven sales lead generator

INSERTION PRICES

DISPLAY ADVERTS	1	4	8
Full Page			
4 Colour	\$3320	\$3225	\$3150
Junior Page			
4 Colour	\$2880	\$2810	\$2740
Half Page			
4 Colour	\$2320	\$2265	\$2215
Quarter Page			
4 Colour	\$1455	\$1425	\$1385

COVER PREMIUM
Inside Front +25%
Outside back +30%

Cover Promotions

Front Cover promotions with Hydraulics & Pneumatics are available to achieve instant impact and portray a powerful message.

Attach a: ■ Belly Band Wrap ■ Booklet ■ CD or Catalogue

We can offer a package to match the required impact. **Price: \$4720**

Inserts

A great way to attract sales leads by inserting your company literature in to the main body of a Hydraulics & Pneumatics issue. Full 10,000 run or split regional runs options available.

Example: A4 sheet to full run \$1575

INSERT RATES

A4 Inserts printed on max' 135gsm	Loose		Bound		A4 Inserts printed on max' 250gsm	Loose		Bound	
2 Pages - Single Sheet	\$1575		\$1895		2 Pages - Single Sheet	\$2345		\$2645	
4 Pages - Double Sheet	\$2705		\$3025		4 Pages - Double Sheet	\$3820		\$4555	
6 Pages - Three Sheet	\$3530		\$3830		6 Pages - Three Sheet	\$4980		\$5280	
8 Pages - Four Sheet	\$4195		\$4490		8 Pages - Four Sheet	\$5785		\$6085	

A5 Inserts (ALL LOOSE)

A4 Inserts printed on max' 170gsm	Loose		Bound		A5 Inserts (ALL LOOSE)			
					135gsm	170gsm	250gsm	
2 Pages - Single Sheet	\$1785		\$2085		2 Pages	\$1115	\$1240	\$1365
4 Pages - Double Sheet	\$3030		\$3320		4 Pages	\$1180	\$1790	\$2350
6 Pages - Three Sheet	\$3960		\$4255		6 Pages	\$2130	\$2405	\$3030
8 Pages - Four Sheet	\$4720		\$5020		8 Pages	\$2700	\$3030	\$3820

Appointments

Are you seeking a Professional within the Fluid Power Industry?

Hydraulics & Pneumatics offers a great platform to source experienced professionals within the Fluid Power Industry.

H&P Appointments offers you:

Over 33,000 Fluid Power Professionals – Consultants, Higher Education, Design Engineers, Sales, R&D, Marketing Management

Most cost effective way to recruit

Every appointment advert booked direct and within H&P Magazine is placed on our website Free Of Charge for 28 days from publication

Established Appointment section for the UKs fluid power industry

KEY FORMATS AVAILABLE

FULL PAGE	\$2360
HALF PAGE	\$1305
QUARTER PAGE	\$795
Eighth page	\$485

Colour insertions + 20%

Don't forget to include:

- Company name (if required)
- Job Title
- Salary and Benefits
- Key Responsibilities
- Attributes
- Contact Details

Spotlights



Have your product, website, news or application story included in Hydraulics & Pneumatics Spotlight pages

- Monthly selection by the Editor
- Full colour image plus 90 words of text
- Telephone number and web address

\$150 per insertion and \$250 to appear inclusive on the website

Spotlights - please contact Nicola Crawley
+44 (0)1732 370340 – nicola.crawley@dfamedia.co.uk

Products & Services

Products & Services Directory offers you:

- Continued presence in the UKs only dedicated journal for the Fluid Power Industry
- Quick and effective reader reference
- Full colour listing
- Heading of your choice
- Multiple entry options available
- Cost effective sales lead generation
- Inclusive on website

100 x 32mm – 4 colour entry – 12 month schedule \$910

Web Locator



Promote your website all year round!

- Increase traffic/interest from your industry!
- Showcase your Homepage with a Screenshot!
- Full Colour Images
- Selection of Headings
- Low cost advertising for your webpage - "one off" payment covers the advertising for the year!
- Inclusive on website

Screenshot and Linage Entry \$630

Linage Entry only \$350

Mechanical Data

Full Page

Bleed 303 x 216
 Trim 297 x 210
 Type 254 x 178

Half Page Horizontal

Bleed 152 x 216
 Trim 146 x 210
 Type 124 x 178

Half Page Vertical

Bleed 303 x 102
 Trim 297 x 96
 Type 254 x 86

Third Page

Horizontal 80 x 178
 Vertical 254 x 72
 Vertical Bleed 303 x 78
 Vertical Trim 297 x 72

Quarter Page

Standard 124 x 86
 Horizontal 59 x 178
 Vertical 254 x 43
 Vertical Bleed 303 x 58
 Vertical Trim 297 x 52

Junior Page 190 x 130

Double Page Spread

Bleed 303 x 436
 Trim 297 x 420
 Type 254 x 394

Half Page Spread

Bleed 152 x 436
 Trim 146 x 420
 Type 124 x 394

(Dimensions - height x width mm)

MATERIAL REQUIREMENTS

Printed Web Offset.
 Advertising copy can be supplied as QuarkXpress or InDesign files (including all support files and fonts), high-resolution, press-optimized pdf, eps, tiff or jpg files. All graphics should be supplied at 300dpi at size to be used.
 All colours should be CMYK or grayscale for mono.
 Please also supply a colour proof to the Production Manager as we cannot be held responsible for any colour variations otherwise.

Copy Deadlines

ADVERTISING COPY DEADLINES

All advertising copy needs to be supplied in the correct format by the end of the third week of the month preceding the issue date. For example for the September issue all ad copy needs to be supplied in the correct format by 12th September.

EDITORIAL SUBMISSION INFORMATION

All editorial submissions must be emailed to the editor by the first Friday of the month preceding the issue date. For example the deadline date for the October issue is the 7th October.

Digital Media

Hydraulics & Pneumatics website:
www.hpmag.co.uk
 incorporating turnpage digital issue.

The H&P website will feature: –

- Breaking news stories on business, legislation and relevant products unique to this website.
- New rich media content – relevant moving media for fluid power industry
- News on up and coming events
- Buyers Guide on line – the digital replication of H&P’s printed version – the most comprehensive and easy to use guide for the fluid power industry.
- The best features and application stories from recent issues of H&P

Online rates

Video Corner Your chance to profile your company video

Unique chance to promote your company video or case study from \$500 per month

Costs are per month	3 months	6 months	9 months	12 months
Headline Banner 950pxl x 120pxl	\$640	\$600	\$560	\$520
Banner Top Centre 600pxl x 150pxl	\$480	\$440	\$400	\$360
Banner Bottom Centre 600pxl x 150pxl	\$400	\$360	\$320	\$280
Top Left Hand Column 300pxl x 200pxl	\$360	\$320	\$280	\$240
Left Hand Column 300pxl x 200pxl	\$320	\$280	\$240	\$200
Video Box	\$640	\$600	\$560	\$520



DFA Direct

Aftermarket **Drives&Controls** **Hydraulics&Pneumatics**
THE JOURNAL OF FLUID POWER AND SYSTEMS

OFFSHORE DESIGN & ENGINEERING EQUIPMENT
PROCURE • BUILD • UPGRADE • MAINTAIN www.offshoreeuropejournal.com

Plant&Works
Engineering



Proven sales lead generator

Drive traffic and interest to your website and product

Target your campaign from a pool of 80k+ named individuals across DFA Media's engineering titles

Select from:

- Job Function
- Areas of Interest
- Geography
- Company Size

Select from E-Cast, Postal or Telephone.

- Target your campaign to the second, direct to you clients
- Ability to interrogate results and measure campaign
- Plan for future programs with confidence

Direct Mail/List Rental

Available for: \$320 per thousand

Media E-Cast rate

Price: \$660 per thousand

Telephone Campaign

Generate current interest to your company product. **Price: On application**

For more information please contact: Ian Atkinson: t: 01732 370340 f: 01732 360034 e: ian.atkinson@dfamedia.co.uk



our portfolio

Head office
DFA Media Ltd
192 High Street,
Tonbridge,
Kent
TN9 1BE UK

t: +44 (0)1732 370340
f: +44 (0)1732 360034
info@dfamedia.co.uk



Contacts

EDITORIAL

Editor

Ed Holden tel/fax: 01892 615806 ed.holden@dfamedia.co.uk

Editorial Assistant

Nicola Crawley nicola.crawley@dfamedia.co.uk

ADVERTISING

Commercial Director

Ryan Fuller ryan.fuller@dfamedia.co.uk

Senior Sales Executive

Andrew Jell andrew.jell@dfamedia.co.uk

PRODUCTION

Chris Davis chris.davis@dfamedia.co.uk

DFA DIRECT

Ian Atkinson ian.atkinson@dfamedia.co.uk

ADVERTISING OVERSEAS

Germany

Victoria Hufmann tel: 911 939 76442 fax: 911 939 76459 victoria@hufmann.info

Eastern USA

Karen C Smith-Kernc tel: +1 717 397 7100 KarenKCS@aol.com

Western USA and Canada

Alan A Kernc tel: +1 717 397 7100 AlanKCS@aol.com

Italy

Oliver & Diego Casiraghi tel: +39 031 261407 fax: +39 031 261380 info@casiraghi.info

Turkey:

intersmart media

tel: 0044 (0)161 764 4160 skype: intersmartmedia meltem@intersmartmedia.co.uk



192 High Street, Tonbridge, Kent TN9 1BE UK
tel: +44 (0) 1732 370340 fax: +44 (0) 1732 360034



Working in co-operation with the British Fluid Power Association & British Compressed Air Society to provide up to date news & developments.

